

Modification Code J4 —Tipper Bodies (Design)

1. Scope

This modification code provides the standards that **manufacturers must meet** when designing and **manufacturing** tipper bodies. It provides standards relating to all aspects of tippers such as safety, hydraulic, warning devices, etc.

These standards are to be followed when designing a tipper body for a motor vehicle. When certifying a motor vehicle OEM tipper body (including a modified OEM tipper body) to the OEM's design requirements only J1 certification is required

Modifications covered under this code:

Covered

- Certification of a motor vehicle tipper body [assessment of design](#).

Not covered

- Fitment of a tipper body (see VSB6 Modification Code J1)
- Fitment of an OEM tipper body (including a modified OEM tipper body) to the OEM's design requirements (see VSB6 Modification Code J1)
- Fitment of non-tipping bodies (see VSB6 Modification Code J1)
- Design of tilt slide bodies (see VSB6 Modification Code T2)
- Fitment of tilt slide bodies (see VSB6 Modification Code T1)
- Fitting a tipper body to a trailer

2. Related standards

Modified vehicles must comply with all ADRs, Australian Standards, acts and regulations. Below are some but not all of the areas that may be affected by the modifications in this code and require certification testing or evidence to demonstrate compliance.

The certifier must ensure that the modified vehicle continues to comply with all related Australian Design Rules and VSB6 codes.

This...	Must comply with...
Installation of lighting and light-signalling devices on other than L-group vehicles	ADR 13/..
Rear vision mirrors	ADR 14/..
General Safety Requirements	ADR 42/..
Vehicle dimensions.	ADR 43/..
External Projections	ADR 92/..
Chassis modification	VSB6 Modification Code H
Exhaust repositioning	VSB6 Modification Code A4

3. Certification procedure

The certification procedure for this modification code is as follows:

1	Modifier	Determine if the tipper body has had previous J4 certification or is an OEM design. <ul style="list-style-type: none"> • If yes, proceed to step 2. • If no, proceed to step 3.
2	Modifier	Contact an accredited J1 AVE to organise the vehicle to be inspected and the tipper body installation certified. Proceed to step 7
3	Modifier	Consult with an accredited J4 AVE for guidance on J4 requirements.
4	Modifier	Design the body in accordance with the J4 design code.
5	J4 AVE	Review manufacturer's design and certify design meets J4 requirements and issue a modification certificate and associated documentation.
6	Modifier	Construct the body and perform modification to the vehicle in accordance with J4 design.
7	Modifier	Contact an accredited J1 AVE to organise the vehicle to be inspected and the tipper body installation certified.
7	J1 AVE	J1 AVE issues modification certificate, affixes modification plate, and submits paperwork as required by the relevant AVE registration scheme.

AVEs must be satisfied that the [design vehicle modification](#) requirements are being met. [AVEs can rely on various sources to verify this, including testing report, engineering reports, manufacturer's specifications, etc.](#) It is advised that before design or modifications begin the modifier discusses the design/modification with the certifying AVE.

4. Certification requirements

Required:

- Develop and provide a package of documentation (J1 document package) that provides all necessary information to allow a J1 AVE to:
- identify the make/s and model/s the tipper body design covers.
- ensure the design complies with all relevant regulatory requirements, including this section of [VSB6](#).
- ensure the installation meets the specified design (installation instructions).
- a circuit diagram for the hoisting system, indicating test points where fitted, [and](#)
- provide the customer with any required maintenance schedule for the tipper body systems (hydraulic, etc).

4. Design requirements

In addition to [manufacturers](#) designing their tipper body in accordance with the mounting requirements of VSB6 Modification Code J1, the below section [must also be](#) followed.

Some work sites may require tipper to meet additional Australian Standards or workplace health and safety requirements. It is recommended that operators ascertain operating conditions, standards applicable, or other procedures applicable to the tipping body, and discuss with the Approved Vehicle Examiner prior to the start of manufacturing.

Tipper bodies should have a continuous sub-frame mounted securely on the chassis. The sub-frame should be mounted by outrigger or mounting (fish) plates that provide a strong integral structure for mounting attachments such as hoist, tipper body pivots and guide brackets. (see Figure 21)

All loads should be distributed over the maximum possible length of the chassis.

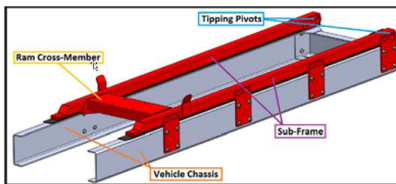

Figure 21- Basic Tipper Sub-Frame

Required:

- Where a sub-frame is used, the leading edge must provide a progressive load bearing transition to prevent truck chassis damage as outlined in J1
- Where a sub-frame is used, it must be appropriately mounted to sustain loads encountered during tipping operations.
- A suitable means of preventing the front of the body from moving side to side must be fitted.
- The hoist ram cross-member must be of adequate strength to support the tipping hoist ram without deforming under all loading conditions.

One method of strengthening ram cross-members is by adding strengthening ribs (see figure 22).

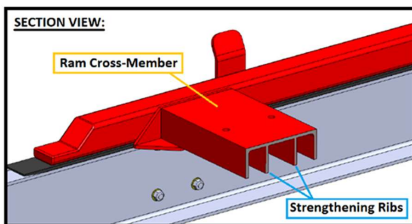

Figure 22 - Cross Section of Ram cross-member w/ strengthening ribs

- Ensure forces experienced on pivots during tipping do not overstress the chassis
- If support brackets (Figure 23) are used, ensure they are designed to allow the centre line of the body-runners pass through the centre of any support structure and evenly distribute the load.

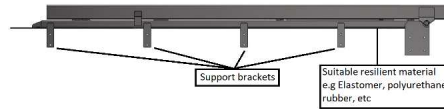

Figure 23 – Example of Support Bracket configuration

- In the absence of truck manufacturers body mounting guidelines, all fasteners must be a minimum ISO Grade 8.8 bolts (or SAE Class 5), hardened washers and self-locking locking nuts. (refer Section H for drilling of chassis)
- Where appropriate, the original truck cross-member should be retained and/or re-installed if the rear cross-member overhang is shortened.

Some rear cross-members fitted by OEMs may not be for structural purposes. To determine if these members can be removed guidance should be sought from the vehicle manufacturer.

Recommended:

- Body guides (guide vanes) are one method to prevent the front of body from moving side to side (see Figure 24).

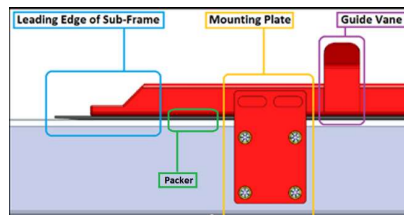

Figure 24 - Example of a suitable sub-frame leading edge, mounting Plate and Body guide (Guide Vane). Note additional examples in Modification code Section J (11)

- For steel bodies, it is recommended that the body guides (guide vanes) be manufactured from steel, flared out at the top to guide the body into place and welded to the sub-frame. For aluminium bodies, guides should be of a suitable material that minimises damage (e.g., rubber guides).
- Mounting plates should be suitably attached to the sub-frame near the hoist ram cross-member to provide restraint during tipping operations and affixed to the truck chassis as per the truck manufacturers' body builders guide (where available).

It is preferred that mounting plates are welded to the sub-frame. However, were bolted the AVE must ensure the attachment is suitably design (crush tube, self-locking nuts, etc)

- Consideration should be given to the location of fish plates, as cracking may occur if they are located in regions that need to be torsionally flexible.
- Tipping pivot sleeves should be incorporated into the rear mounting plates to prevent tearing out of the pivot walls of the sub-frame. Where a longer single pivot passing through both pivot sleeves is used, reinforcing is not generally required. However, where two separate pivot pins are used (one for each pivot) reinforcing is typically required.
- Use longitudinal packers (of a suitable material) on the chassis to distribute tipper body loads evenly wherever practicable (see Figure 24).

- For tipper bodies without longitudinal packers, the design should distribute tipper body loads evenly wherever practicable.
- The base of the hoist cylinder should be pin-jointed to a cross-member that is attached to the side rails with bolts through drilled and reamed holes in the vertical webs of the chassis. (see Figure 25)
- Pivots should be supported by the vehicle's chassis.
- To further evaluate the strength of the body Finite Element Analysis (FEA) software may be used.

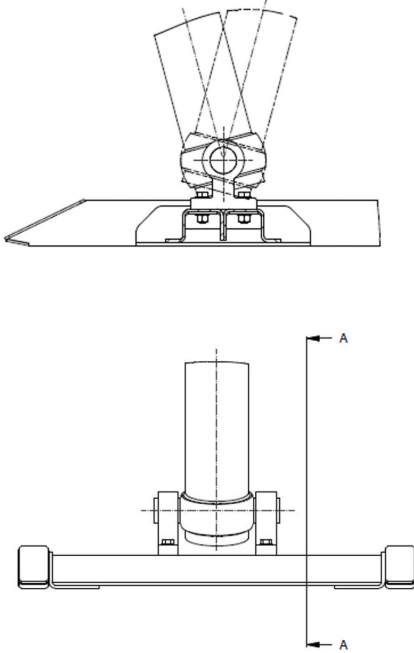

Figure 25 - Typical installation of the hoist cylinder.

5. Body Props

A body prop must be fitted to provide, when necessary, a safe operating environment when the empty tipping body is lifted. Such as when the vehicle is undergoing routine maintenance.

- The body prop is not intended to be deployed when the tipping body is loaded.
- In the event of hydraulic failure during operation, and the tipping body cannot be unloaded, specialist equipment and appropriate work procedure must be used to conduct repairs in a safe manner.

- A body prop forms part of a system that ensures a safe working environment under the tipping body during service, maintenance and repairs.
- Failure of a body prop poses significant and fatal risk to persons working under the tipper body. It is essential that the prop is secured (at both ends) and fit for purpose.

Required:

- A body prop must be fitted that:
 - along with its associated hardware, is designed so that

Vehicle Standards Bulletin 6 — Version 3.2.1

Section J — Body

- strength calculations account for a minimum factor of safety of 2 with respect to the empty weight of the unladen tipping body.
- can be deployed when the tipping body is at an appropriate angle to facilitate such activities as servicing of the body hoisting system, etc.
- ensure that it is not possible to mistakenly place the prop in a location at which it is not effective.
- allows easy deployment, without having to excessively reach under the tipping body.
- is secured against accidental dislodgement when in use.
- when not in use, can be securely stowed either to the tipping body or the vehicles chassis (it is not required to store the prop adjacent to the hoisting ram).

Recommended:

- The body prop is permanently connected to the vehicle

6. Tail Gates, Grain, and Inspection Chutes.

Required:

- The tailgate and its locking mechanism must be designed to withstand the forces and operate without loss of function (such as spillage or the tailgate opening) when tipping.
- If the tailgate includes an auxiliary door (grain chute, viewing portal etc.), then the locking mechanisms of the auxiliary door (as a system) must be designed to withstand the forces and operate without loss of function when tipping.

Recommended:

- When designing the tailgate and locking mechanism to operate without loss of function it is recommended that it is designed to accommodate, at least, the following conditions:
 - the tipping body is loaded to its maximum design carrying capacity (loaded to GVM) plus 25%
 - the tipping body is at its maximum design tilt angle (or the tilt angle it is restricted to by other means).
 - the vehicle is on level ground.

⚠ Consideration for the loading conditions that the tailgate will be subjected to will be dependent upon the material the tipper has been designed and must also take into account partial loading of the tipper body, or mixed loads.

7. Load Cells

Load cells are often incorporated into ram and tipping pivots between the ram cross-member and the ram itself. Therefore, the nature of the loading experienced by the ram cross-member is generally unchanged. However, care must be taken to integrate the load cells into the sub-frame to prevent point loading the rear of the truck chassis.

⚠ Some designs include suspension-based load sensing systems. These systems are not required to be certified under the J code. However, depending on their design may require certification under alternative VSB 6 codes.

Required:

- Where load cells are incorporated into the tipping pivot, load cells must be mounted in a manner that maintains the structural integrity.
- Examples of acceptable load cell incorporation include, but are not limited to the following:
- **Example 1:** Tipping pivot/load cell must be mounted onto brackets of adequate strength with a suitable cross-member installed between the brackets (see Figure 26)

Commented [MR1]: Body props are an AS1418.8 requirement for servicing.

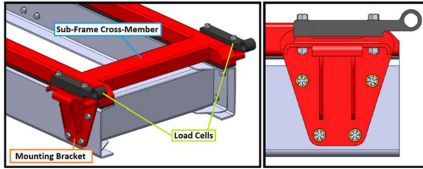

Figure 26 - Option 1 Example: Load cells w/ integrated pivot mounted on brackets & integrated into sub-frame

- **Example 2:** A portion of the rear sub-frame can be removed to accommodate the load cell and modified to maintain structural integrity. (see Figure 27 and 28)

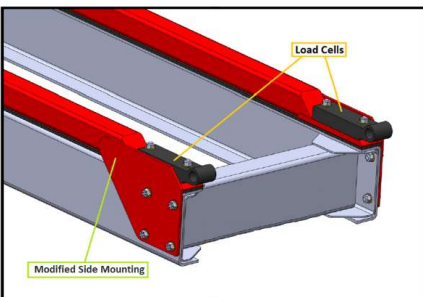

Figure 27 - Example of load cells mounted to modified sub frame that maintains structural integrity. In this example, by enlarged and thickened mounting plates with upside down countersunk fasteners to prevent bolting through chassis flange)

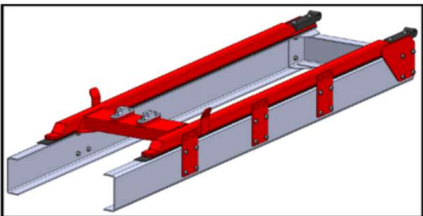

Figure 28 - Tipper sub-frame with integrated load cells

- Drilling of top or bottom chassis flange to mount load cell is not permitted.

Recommended:

- Load cells should be mounted using upside down countersunk fasteners with a minimum ISO Grade 8.8 (or SAE Class 5), appropriate grade washers and self-locking nuts (see AS 1110.1). (see Figure 29)

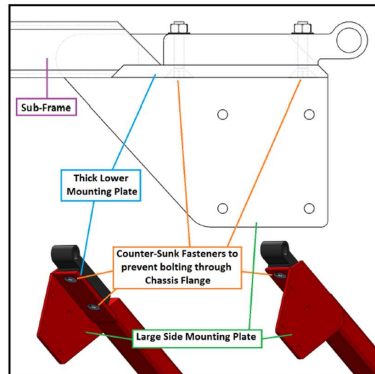

Figure 29 - Countersunk fasteners to prevent bolting through chassis frame

- Lower mounting plates should be integrated into the sub-frame.
- Side mounting plates should extend forward of the region where the sub-frame was removed.
- Edges of the sub-frame, lower mounting plates and side mounting plates should overlap

8. Hydraulics/Pneumatics

Required:

- The general design principles of AS2671 must be followed, with the following specific design considerations for tipper.
- When there is a complete loss of pressure in the hydraulic system (hose burst etc.), the lifting hoist must either:
 - immediately stop moving; or
 - the lifting command on the control be disabled or made ineffective. Lowering of the body can be achieved in a controlled manner by applying the usual lowering command on the control, provided the operator can stop and restart the descent of the body at any point.
- Where a system is designed to immediately stop moving in the event of complete loss of pressure and the release mechanism is in a position that may put operators in an unsafe position, a label must be affixed in a visible location(s) on the side of the body immediately adjacent to the release mechanism advising such. (refer to Section 12 Marking for requirements and guidance)
- Where the power supply of an accessory, such as a powered tailgate or its lock, is interrupted through electrical or mechanical failure, the accessory must not **continue to operate in an uncontrolled manner. (e.g., powered tailgate must not automatically close (or move) when de-energised result in a hazardous situation).**
- An accessory may return to a neutral position automatically when de-energised only if it **does not result in a hazardous situation would not pose a safety risk.**
- Tipping bodies or accessories which use the truck's compressed air for their operation, must be designed to be compatible with the normal nominal operating pressure of the truck's pneumatic system.
- Air supply must be taken from a pressure protected supply as per the requirements of VSB6 Section G.
- Hoses and fittings must be sized accordingly, or appropriate pressure reducers fitted as required to prevent cavitation,

Commented [MR2]: Amended wording inline with AS2671

starvation and undue temperature rises of the fluid in the system.

- Hoses and fittings must meet recognised standards.
- Components, gauges, pressure test points or any other item requiring daily monitoring or adjustment, must not be placed in locations which put the operator at risk.
- Hydraulic components must operate within component manufacturer's rated specifications.
- Where a pressure relief valve is used it must have adequate flow to prevent overload under every engine operating condition.

Recommended:

- Pneumatic and hydraulic lifting systems should incorporate over pressure protection set to at least 10% below the lowest rated component in the hydraulic/pneumatic system but sufficient for the maximum operating hydraulic circuit flow rate.
- Once hydraulic pressure, corresponding to the tipping body (including an acceptable overpressure) is reached, the tipping mechanism should stop operating.
- Unless the air supply is derived from the pneumatic system, air pneumatic filter/separators should be provided and be sized to provide at least 1000 hours operation between services (preferably with condition indicators).
- Provision to bleed air from the system/hoist is provided if applicable.
- The system must have a level indicator (e.g., a decal, dip stick, plates or marking) showing maximum and minimum levels under operational conditions
- Hydraulic tanks:
 - have a level indicator (e.g., a decal, dip stick, plates or marking) next to the filling position showing maximum and minimum levels under operational conditions.
 - hold a minimum amount of oil for full ram displacement plus 30%.
 - provide adequately protected and accessible provisions to facilitate emptying of the tank without spillage, complete cleaning or requiring pumping out of fluid.
- The hydraulic tank return circuit is designed in a way that minimises the possibility of oil aeration.
- A red tell-tale light in the vehicle cab which indicates when the overpressure set point is reached.
- Hoses should be shielded to reduce direct exposure to personnel in the event of failure where:
 - fluid pressure is above 5 MPa (726 PSI); or
 - fluid temperature is above 50°C.

↘ Protection may be via a shielding provided by body work or the vehicle chassis, metal shielding, anti-burst sleeves (or anti burst socks) designed for this purpose, or a combination of any of the above.

- Where hydraulic components are fitted that are sensitive to debris in the system, hydraulic filters should be fitted.
- If hydraulic filters are fitted they should have the ability to be changed without disturbing hoses or emptying the hydraulic tank.

9. Alarms, warnings and lockout features

Recommend:

- Tailgates fitted with positive locking mechanisms (mechanical, air or electric) should be fitted with a visible and/or audible tell-tale located at the tipper controls which warns the operator when:

- the tailgate is locked, and the front of the tipping body is in the raised condition (50mm or more above its transport position); or
- automatically unlock the tailgate when the body begins to rise.

10. Controls

Required:

- Control systems must provide fail-safe operation at all times (including during a failure the system, power supply, etc.)
- If the tipping body is not designed to tip in motion the control device must:
 - be positive in motion hold-to-run type; and
 - return to neutral when released
- If the tipping body is designed to tip in motion must be designed in a way that minimises operational risks and accidental operation of the tipping body.

↘ It is understood that in many cases return to neutral and hold to operate controls in certain tipper applications is not practical or safe. For example:

- Side tipping applications where the operation of other equipment requires hydraulic flow to remain established and additional controls must be used to operate hydraulic powered equipment (e.g., side gates).
- Tipping in motion where the vehicle must continue to move while tipping and driver must continue to steer the vehicle.

Section J4 permits the fitting of controls that are not "return to neutral", or "hold to operate" provided that the operational risks of accidental activation of controls (while the vehicle is in motion) have been assessed and sufficient mitigation included.

Examples of methods to minimise operational risk include, but are not limited to the following:

- a body interlock system should be fitted that stops the vehicle moving at a speed greater than 20km/h if the body is not in its transport position; or
- A body up visual warning in the cab, that activated when the body is not in its transport position.

- If controls are fitted in multiple locations, interlocks must be fitted to ensure only one set of controls can be used at once.
- If external mechanical controls or the controls designed to allow operation from outside the cab are fitted, they must:
 - be able to be secured from accidental operation by a locking mechanism when not in use.
 - not operate the tipping body whilst the vehicle is in motion; and
 - not be located in a position hazardous to the operator when used.
- If a pendant or remote control is fitted, they must:
 - be fitted in an appropriate enclosure with no less than IP55 rating
 - return to the off position if the control is released, detached, or broken
 - not allow unintended movement due to failure of the controls (monitored outputs)
 - have an emergency stop
 - shutdown the system within 550ms if no valid signal is received from the transmitter
 - have key-stop to 'off' position
 - shut down if transmitter is out of range
 - have battery life indicator (if fitted with a battery) that gives warning at least 5 minutes prior to turning off
 - turn off if no functions have been used for 5 minutes; and

Commented [MR3]: This item is a relaxed requirement taken from AS2671

- not be able to be initiated unless all motion actuators are in the 'off' position (buttons/switches/ hydraulic valves, etc.)

11. Marking

Required:

- The hoisting system shall display, at a readily accessible and prominent location/s and on permanent and legible notices, the following information, as appropriate:
 - Name or mark of the manufacturer or distributor of the hoisting system.
 - Model designation of the hoisting system.
 - A notice stating that 'PERSONS SHALL NOT WORK UNDER THE RAISED TIPPING BODY UNLESS THE BODY HAS BEEN SECURELY CHOCKED OR OTHERWISE SECURED'; and
 - Where applicable, a notice stating 'PERSONNEL SHALL NOT RIDE ON THE TIP TRUCK'
- A permanent and legible label in a prominent location/s near the controls must be fitted advising the operator to 'ENSURE THE AREA AROUND THE TRUCK IS CLEAR DURING TIPPING OPERATIONS'.

12. Stability

Recommended:

A truck fitted with a tipping body should have an overturn angle of 7° or more when the tipping body is raised to the full stroke of the tipping hoist. This can be met in a variety of ways, some of which are included below.

- ✎ It is impossible to foresee all operating conditions that a vehicle fitted with a tipping body due to the broad range of environmental factors such a vehicle will encounter. This may include:
 - Construction sites with uneven and soft ground
 - Wet and muddy work sites
 - Hard uneven surfaces
 - Hard level surfaces
- ✎ When assessing the design, the best-case scenario should be considered to provide a baseline pro-forma criterion. Assessing this baseline. They will not result in a safe vehicle during in all operating conditions.

There are many ways that the vehicle's baseline stability can be considered, one of the following methods should be used.

Equipment

- The vehicle may be fitted with a device, such as an inclinometer, that:
 - is interconnected with the tipping mechanism and will prevent the body from raising any further if loss of lateral stability is detected.
 - The inclinometer outputs a signal to a buzzer or other sound generator within the vehicle cabin which may also incorporate a tell-tale.

✎ Many electronic brake systems have a stability function incorporated with an output that can be utilised to activate a warning signal (buzzer, light etc) or interlock. This signal may be used in lieu of a dedicated inclinometer if performed in accordance with the brake manufacturer's requirements.

Calculation

- The vehicle's design should be assessed using calculations to ensure an overturn angle of at least 7°.
- One calculation method is provided in Section 13, however suitably qualified AVEs may choose to use alternate stability calculation methods. These calculations assume:
 - the tipping body is loaded with a simulated water load to the trucks' maximum GVM
 - the body is in its fully tipped position.
 - Wind loads are considered for the purposes of AS1418.8 Clause 4.3, unless the lifting ram accepts only axial loads.

13. Stability calculations

THIS SECTION IS STILL UNDER REVIEW BY THE NHVR. ONCE FURTHER INFORMATION IS AVAILABLE IT WILL BE CIRCULATED.

J4 Checklist — Tipper (design) (example)

J4 Checklist — Tipper bodies (Design)

This checklist is for use by approved vehicle examiners (AVEs) when certifying the design of a tipper body.

Vehicle and modifier details

Vehicle make:	Vehicle model:	Month and year of manufacture:
VIN (if applicable):	Vehicle chassis no. (if applicable):	Vehicle modifier (company name):

Advanced braking systems

Braking systems	Check Yes, No, N/A as applicable:	Yes	No	N/A
1 Is the advanced braking system (where fitted) un-affected or re-certified after the vehicle modification?		<input type="checkbox"/>	<input type="checkbox"/>	<input type="checkbox"/>

Modification details

Modification criteria	Check Yes, No as applicable:	Yes	No
1 Has the modification been performed in accordance with the manufacturer's guidelines (body builders guide, etc)?		<input type="checkbox"/>	<input type="checkbox"/>

Installation details

Tipper design	Check Yes, No, as applicable:	Yes	No
1 Does the leading edge of the sub frame provide a progressive load bearing transition?		<input type="checkbox"/>	<input type="checkbox"/>
2 Is the subframe appropriately mounted to sustain loads encountered during tipping?		<input type="checkbox"/>	<input type="checkbox"/>
3 Does the design specify that all bolts are required to be a minimum SAE Class 5 or ISO Grade 8.8?		<input type="checkbox"/>	<input type="checkbox"/>
4 Do the tipper body mounting brackets ensure the load is evenly distributed across the chassis?		<input type="checkbox"/>	<input type="checkbox"/>
5 Does the design incorporate a complying body prop?		<input type="checkbox"/>	<input type="checkbox"/>
6 Is the tailgate and auxiliary door (if fitted) designed to meet all force and operating requirements when tipping?		<input type="checkbox"/>	<input type="checkbox"/>
7 If the lifting hoist experiences a complete loss of hydraulic pressure does it: <ul style="list-style-type: none"> - immediately stop moving; or - disable the lifting command on the control but continue to allow controlled lowering of the body? 		<input type="checkbox"/>	<input type="checkbox"/>
8 Are control systems designed to provide fail-safe operation at all times?		<input type="checkbox"/>	<input type="checkbox"/>

Compliance

Modification	Check Yes or No as applicable:	Yes	No
1 Does this design meet all the requirements of the manufacturer's guidelines / Modification Code J4?		<input type="checkbox"/>	<input type="checkbox"/>
2 Does the vehicle continue to comply with ADRs and heavy vehicle standards regulations affected by the modification?		<input type="checkbox"/>	<input type="checkbox"/>

Authorisation

Other than modification criteria, if the answer to any relevant question is NO the modification is not acceptable.

Comments:

Examined by:	Company (if applicable):	AVE no.:	
Signed:	Modification certificate no.:	Modification plate no.:	Date:

Vehicle chassis no./VIN:	Date:	Signed:
--------------------------	-------	---------