

# Key safety and compliance areas under Chain of Responsibility

Adam Ritzinger – Chief Technical Officer, HVIA

ATA Industry Technical Council  
31 March 2023



**HEAVY VEHICLE**  
INDUSTRY AUSTRALIA



Who has CoR responsibilities?



**HEAVY VEHICLE**  
INDUSTRY AUSTRALIA

# What does the law say?

*Primary safety duty*

*Section 26C*

*Ensure the safety of transport activities*

*Do whatever is reasonably practicable*

Section 26C of the HVNL imposes a primary safety duty on each party in the chain to **ensure**, so far as is **reasonably practicable**, the safety of the party's transport activities.



# Key areas for operators

- Load restraint



- Fatigue/distraction



# Load restraint

- Who specifies packaging requirements?
- Who decides how your customer's freight should be restrained?
- Who checks to see if the applied restraints are appropriate?
- How are those parties trained?
- What procedures/documents cover packaging and restraint?
- Have you considered 'engineered' solutions?



# Load restraint

- Packaging must withstand the same forces as restraints
- Either the freight owner or the transport company can produce a packaging and load restraint procedure
  - *Ideally, do it together!*
- Engineered solutions are available for many applications



Gap filled with pallets

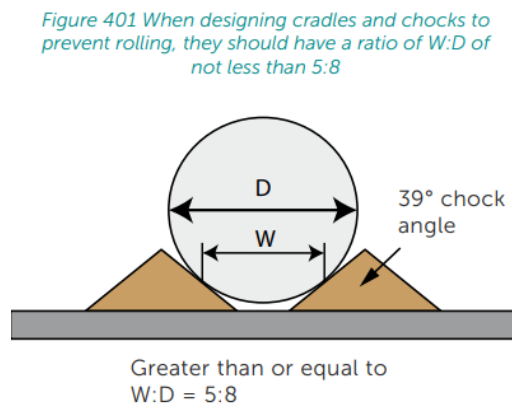
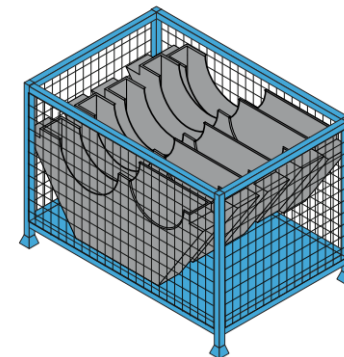
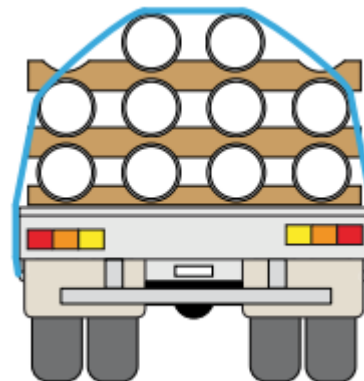

Figure 401 When designing cradles and chocks to prevent rolling, they should have a ratio of W:D of not less than 5:8



# Fatigue/distraction

- What is your policy on driving/working hours?
- What is your policy on use of mobile devices?
- Who sets the roster/schedule? Does your customer have any influence?
- How do you monitor working hours?
- Do you measure/monitor fatigue or distraction?



# Fatigue/distraction

- Policies on the hours limits for each state/operation
- Use of mobile devices policy – evolving area
- Customers that control delivery times is a risk
- Use web-based tools to check work diary compliance
- Use technology to manage fatigue/distraction – work diaries cannot do it alone!

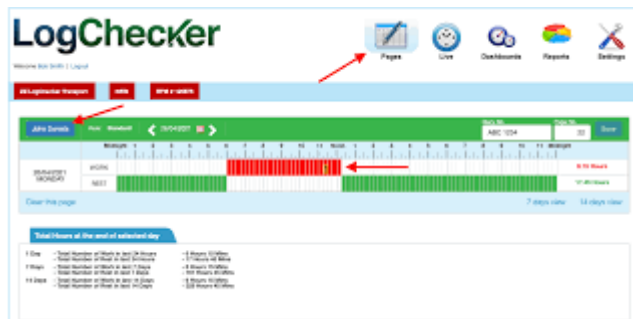

# Questions



**HEAVY VEHICLE**  
INDUSTRY AUSTRALIA